

MECHANICAL ACCESSORIES

Filter boxes and filters

DIMENSIONS (mm)

Type	A	B	Ø	C	D
FLF 100	170	202	100	530	430
FLF 125	205	212	125	535	430
FLF 160	235	262	160	555	450
FLF 200	275	312	200	620	500
FLF 250	325	362	250	680	560
FLF 315	390	423	315	745	625
FLF 400	495	513	400	765	635

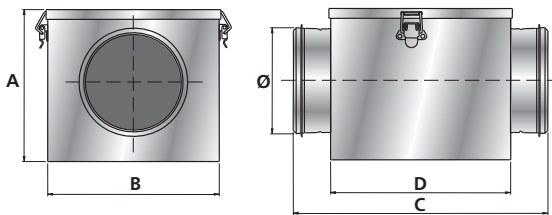

FILTER BOX, FLF

The FLF filter box is manufactured from galvanized steel sheet. It is delivered without filter.

FLF is available in sizes 100, 125, 160, 200, 250, 315 and 400.

BAG FILTER, FLF

The FLF bag filters are to be used in the FLF filter boxes. There are three different filter classes to choose from: G4, F5 and F7, where F7 is the finest.

PRESSURE DROP G4-FILTER

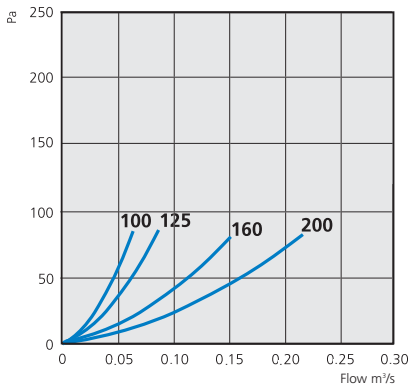

PRESSURE DROP F5-FILTER

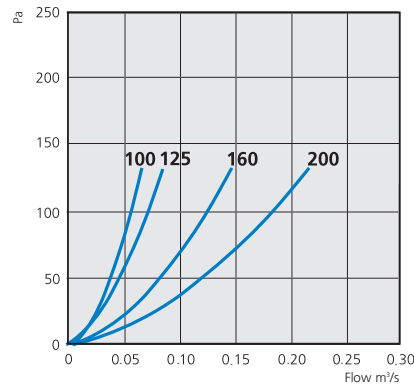

PRESSURE DROP F7-FILTER

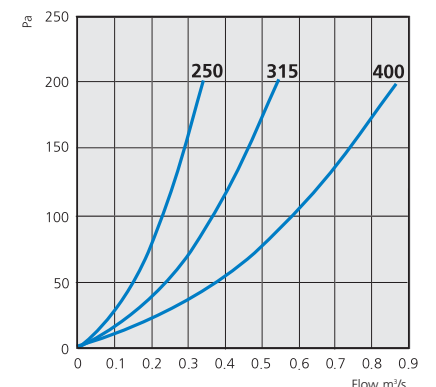
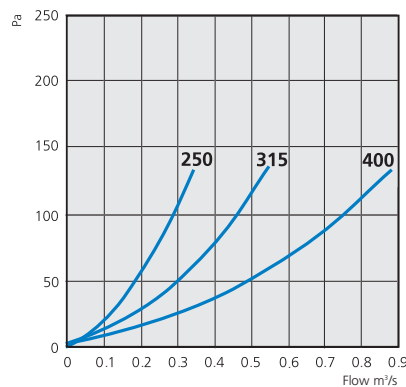
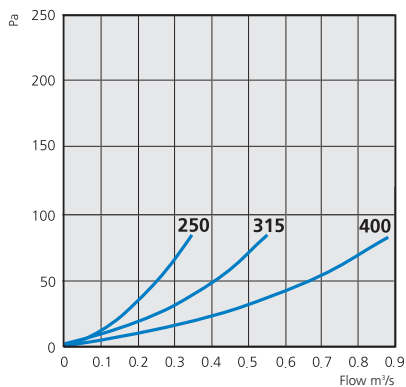
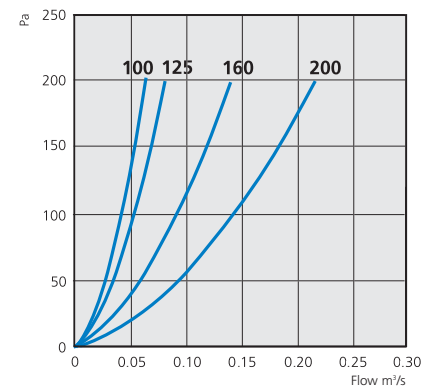

MECHANICAL ACCESSORIES

Filter boxes and filters

FILTER BOX, FLK

The FLK filter box is manufactured from galvanized steel sheet. It is delivered with a G4 filter.

FLK is available in sizes 100, 125, 160, 200, 250, 315 and 400.

FILTER, FLK

The FLK filters are designed for use in the FLK filter boxes. There are two different filter types to choose from: standard and cleanable filters. Clean-able filters are easy to clean and are commonly used in tumble dryers, etc.



DIMENSIONS (mm)

Type	A	B	Ø	C	D
FLK 100	170	205	100	227	120
FLK 125	205	215	125	252	140
FLK 160	235	265	160	267	155
FLK 200	275	315	200	302	180
FLK 250	325	365	250	352	230
FLK 315	390	425	315	452	320
FLK 400	495	515	400	587	455

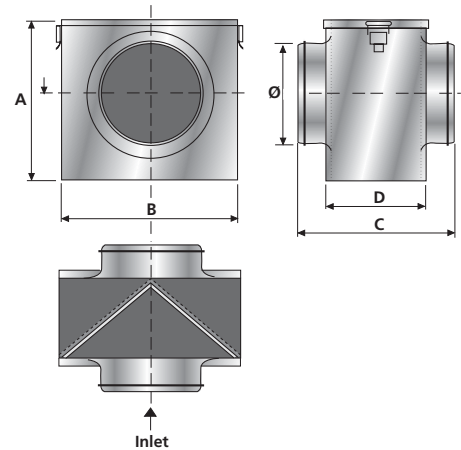

PRESSURE DROP G4-FILTER

